

Utilization Of Renewable Energi By Methode Of Cba (Cost Benefit Analysis) And Electre (Elimination Et La Choix Traduisant Réalité) To Analyze The Electricity Need In The State Border Area

By I Made Jiwa

**UTILIZATION OF RENEWABLE ENERGI BY METHODE OF CBA (COST BENEFIT ANALYSIS)
AND ELECTRE (ELIMINATION ET LA CHOIX TRADUISANT RÉALITÉ) TO ANALYZE
THE ELECTRICITY NEED IN THE STATE BORDER AREA**

Nurchahya Dwi Asmoro¹, Syahrul Abadi¹, I Made Jiwa¹

¹*Indonesian Naval Technology College, Bumimoro-
Morokrempangan, Surabaya 60187, Indonesia
1Cahyoasro416@gmail.com*

ABSTRACT

Along with the growth of the national economy, the greater the demand for electricity supply nationwide. Benefits of electricity that can be used directly in everyday life that is for light, as an energy source, as an entertainment infrastructure, producing heat and as a producer of motion. However, not all electricity needs can be met by the State electricity company (PLN) in view of the new Indonesian electrification ratio reached 88.30% and many inhabited islands were untouched by electricity, one of which is P.Romang in Southwest Maluku district. The results of this study indicate that Romang Island holds the potential of renewable energy, with details for the solar power potential of 5.1 kWh / m² and wind of 5.1 m / s. This potential is feasible to be used for solar power generation and wind power generation fired plant. Therefore, needs electrical energy needs by renewable energy Using the method of cost benefit analysis (CBA) and ELECTRE III result SPP and fired plant to be developed, but more SPP provides benefits in accordance with the results of the calculation method of the CBA. The results of the calculation of NPV and IRR calculations show numbers for SPP is Rp 135,189,336,609.72 (interest rate of 6%), Rp 119,259,549,108.26 (9% interest), Rp 111,332,148,055.47 and fired plant is USD 174 985 410 781, 98 (6% interest), Rp 156,111,067,510.21 (9% interest), Rp 146,025,482,870.77 (11%). IRR for the SPP is 24% (6% interest), 28% (9% interest), 31% (11%) and thermal power station is 23% (6% interest), 28% (9% interest), 31% (interest 11%). This result deserves to be developed against both types of these plants.

Keywords : Renewable energy, solar power, thermal power station, CBA, ELECTRE III

1. INTRODUCTION.

Energy is a fundamental requirement in the modern era, are directly related to the welfare and prosperity of life and the world today requires a large energy supply (Mandal et al., 2017), As well needs national electricity consumption will continue to increase with the growth rate of the national economy. The increase of energy demand in the world in 1970 and the increasing almost doubled in

1997, and the growth of about 57% in 2004 - 2030, it is an alarm for the search for renewable energy sources. That is to overcome the energy crisis when the fuel oil energy source is decreased (Diana, 2012). The electricity consumption is still in the industrial sector, the household sector and the transport sector. Transportation sector that consumes fuel oil energy, now has started to switch and developed vehicles sourced

electrical energy. This further indicates an increase in electrical demand Electricity (Gao & Winfield, 2012). Although the electric-powered vehicles development might not utilized by everyone, but to reduce the fuel consumption of vehicles, it has also developed natural gas-fueled vehicles to reduce the rate of world fuel consumption (Gabbar et al., 2016). Consumption in the household sector is directly proportional to the growth in population. Population growth should also be followed by better economic growth. Beginning from the discovery of steam energy sources up to a source discovery of electrical energy, it has provided significant changes to development in each region, creating new activities and new needs for human life (Mazzeo, 2013). It has shown one way to improve the economy is to fulfill the need of electricity as an energy source for increased productivity and infrastructure supporting the economy.

One of the problems Indonesia is geography position as an archipelago state that makes constraints quite difficult to increase the electrification ratio, especially in eastern Indonesia (Aditya & Addin, 2017). Indonesia's electrification ratio in the country - most regional countries are still relatively low. With the electrification ratio amounted to 88.30%, there are still many Indonesian people who have not enjoyed electricity, when most other people can not imagine how to live without electricity. While the ratio electrification of Singapore 100%, Brunei 99.7%, Malaysia 99%, Thailand 99.3% and Vietnam 98%. Adequate energy needs will always improve living standards for people in all facets of life. This can be evidenced in countries -

developing countries, where the country has been implementing a transition towards greater electrification with consideration of the impact of economic, social, health and the environment. Since energy is a vital factor in production (Best et al., 2017). Countries in Southeast Asia are beginning to recognize the need to diversify their energy sources. This needs to be done to reduce dependence on import energy. Similarly, Indonesia, which began to increase the utilization of natural gas energy sources (Birol et al., 2015). In Table 1.

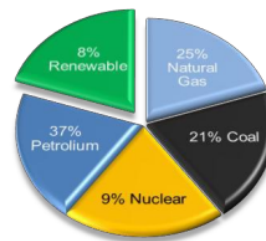

The Energy Policy of Southeast Asian Countries, indicates that the processing and utilization of energy is a thing that must be well planned in the long run.

Fig. 1. Data source of electricity in the world (Banerjee & Choudhury, 2015)

Source of electricity in the world today is still predominantly use fossil fuels, the details of which oil by 37%, natural gas 25% and coal 21%. Nuclear electricity sources 9% and 8% renewable energy sources. Comparison of the electricity source can be seen in Figure. 1 Data Sources of electricity in the world

Table 1. The Energy Policy of Southeast Asian Countries (Biol et al., 2015)

Country	Sector	Policy and targets
16 Brunei Darussalam	Efficiency Renewables	Reduce energy intensity by 45% from 2005 levels by 2035 Achieve 10% of electricity generation from renewable by 2035
Cambodia	Efficiency	Reduce energy consumption 20% from BAU level by 2035.
Indonesia	Efficiency "New and renewable energy" Climate change	Reduce energy intensity by 1% per year to 2025. Increase share of "new and renewable energy" in primary energy supply to reach 23% by 2025 and 31% by 2050. Reduce GHG emissions 26% from BAU level by 2020, increase to 2% reduction with enhanced international assistance.
Lao PDR	Efficiency Renewable	Reduce final energy consumption from BAU level by 10%. Achieve 30% share of renewable in primary energy supply by 2025.
Malaysia	Efficiency Renewables Nuclear Climate change	Promote energy efficiency in the industry, buildings and domestic sectors Increase capacity of renewables to 2 080 MW by 2020 and 4 000 MW by 2030 Government is developing plans and undertaking feasibility, site selection and regulatory studies. Reduce carbon intensity of GDP by 40% by 2020 from 2005 levels.
Myanmar	Efficiency Renewables	Reduce energy demand by 10% from BAU level. Achieve 15% to 18% share of renewables in total generation capacity by 2020.
Philippines	Efficiency Renewables	Attain energy savings equivalent to 15% of annual final demand relative to BAU by 2020. Triple the installed capacity of renewables power generation to 15GW by 2030
Singapore	Efficiency Climate change	Reduce energy intensity by 35% by 2030 from 2005 levels Reduce GHG emissions by 7% to 11% below BAU levels by 2020, which will be increased to 16%, if there is a legally binding global agreement on climate change. Reduce GHG emissions intensity by 36% by 2030 from 2005 levels
Thailand	Efficiency Renewables Nuclear	Reduce energy intensity by 30% compared with 2010 by 2036 through the removal of fossil-fuel subsidies and accelerated energy efficiency improvements. Renewables to reach 20% of power generation by; biofuels to reach 20% of transport fuel use by 2036. Two commercial reactors have been planned since 2007, although progress has stalled since the Fukushima Daiichi accident.
Vietnam	Efficiency Renewables Nuclear	Reduce energy consumption by 5% to 8% by 2015 and 8-10% by 2020 relative to BAU Increase the share of renewables in electricity generation to 4.5% by 2020 and 6% by 2030 Develop 10.7 GW of nuclear power capacity by 2030.

A while electricity in Indonesia is still using fossil fuel / coal and in Indonesia eastern

includes Sulawesi, Nusa Tenggara, Maluku to Papua using a power source of fuel oil / diesel

fuel and the effect of decreasing the production of diesel fuel at the oil refineries in the country, while the demand for diesel fuel requirement increases, it forces the government to import diesel fuel, causing increasing burden of state finances. This condition causes the diesel fuel to be one component of an expensive costs, and the impact on the difficulty of the electricity demand in eastern Indonesia to fulfill. Included also resulted in many areas of unmet electricity demand, especially in PPKT (minor outlying islands). One of them is on Romang Island and surrounding areas, there are included in the subdistrict administrative region Romang Islands, Southwest Maluku district, Maluku Province. Given the Maluku province is the State Border Area with Australia and Timor-Leste, it already should be subject of study to be carried out on all sides, especially the considerations of strategy developments. Actions relating to defense strategy includes planning and organizational development and infrastructure provision, the determination of the best use of resources and sources of procurement, identification of work standards to be achieved, and the establishment of control mechanisms and reporting (Sokolovic et al., 2013). Construction of the power plant is one of the ventures of strategic actions in the form of infrastructure development for the provision of a source of energy / resources. Of course, in the construction in Romang Island Maluku should also refer to the regulations on spatial border area in Maluku Province as stipulated in Presidential Regulation Number 33 of 2015, which explained that the border area in the province of Maluku is a national strategic area, that of national spatial arrangement prioritized for has a very

important influence nationally against the country's sovereignty, defense and resilience of the state, economic, social, cultural or environmental.

With yet insufficient source of electrical energy in Romang Island, it is necessary to find an alternative way out in the form of renewable energy sources as a solution to energy crisis, so that people can enjoy the support of electrical energy sufficient and sustainable. Research this energy source will open up investment projects that can provide benefits and impact on the economic development of the local or regional economy, optimization of transportation flows but it also have negative effects such as population displacement (Andrei et al., 2009). Of course, in meeting the need for energy independence should still be the best solution by using renewable energy sources. Renewable energy is an energy source that comes from nature and directly usable on - time, such as a source of wind energy, solar energy, wave energy, tidal energy, geothermal energy, biofuels energy, and others. In this study will be restricted on the comparison between wind energy and solar energy as a source of electrical energy in Romang Island, Southwest Maluku, Indonesia.

2. MATERIAL AND METHODOLOGY

In the presidential regulation on spatial explained that the border area is an area or region in the form of a national strategic area and is located on the inner side along the state border. Border area in question in this research is an area that is located in Maluku province, bordering the states of Australia and Timor Leste. While the national strategic areas can be defined as spatial arrangement areas

prioritized because it has a very important influence nationally against the sovereignty of the State, defense and resilience of the State, economic, social, cultural, and / or the environment, including areas that have been designated as world heritage, Spatial planning border area in Maluku province has a role as an operational tool and a means of coordination in implementing development in the border area between the Republic of Indonesia, Australia and East Timor. It also serves as a guideline for determining the location and function of investments, as well as management of border area. Development in country border areas should be based on the idea of sustainable development with due regard to social, economic and environmental aspects (seferaj, 2014)

The energy source that has been used is the energy derived from fossil fuels and conventional / it can not be updated. The greater utilization and energy needs of the world it will be faster as well the loss of this energy source. This prompted many of the modern countries to develop and build nuclear reactors as an alternative step for future sources of electrical energy (Shykinov et al., 2016) However, in addition to nuclear energy can also be used as a replacement source of fossil energy is wind energy and solar energy as an alternative source of renewable energy that will never run out utilized, so that it can be interpreted that the definition of renewable energy is energy derived from nature and can be used continuously without any risk of running energy resources.

19

PV (Photovoltaic) is a process to convert the radiant energy of the sun into direct current electrical energy, made of silicon material and given additional layer of special materials. If the sunshine on the cell the electrons out of the atoms and the flow causing an electrical voltage and pass an electric generation effort that can be arranged either in parallel or in series. Given the energy source is the sun then the condition of the electricity generated will be strongly influenced by the weather and the movement of the sun so that the intensity of the sunlight received by the cell will always change, and the generated electric power becomes unstable. PV has been developed and it has been refined of a technology called PVGIS (Photovoltaic Geographical Information System). This type of PV is able to adjust to the sunlight conditions both when the weather is bright and cloudy and also able to adjust the angle of the sun's position elevation so that the process of changes solar radiation into electric current can be more efficient. This PV can produce electricity of 763 kWh per year (Taus et al., 2015) The sun's movement in question is the movement of the sun throughout the year which are always shifting between 23,5° N up to 23,5° S. For the geographical position of Indonesia in the region around the equator, the effects of this condition does not causes too big difference, but for a country that geographical located at high latitudes away from the equator, the effect of these differences become apparent. See bellow to the Figure 2. The orbit of earth around the sun.

15



15

Fig. 2. The orbit of the earth around the sun (Mendez, 2016)

However, the source of solar energy produced from Solar PV is a very good technology and should be utilized to increase the supply of electricity whenever possible (Rutkowski, 2016). Therefore some of hybrid system are combined with an electric power source other to strengthen the power of a solar power plant (SPP), for example SPP - Genset, SPP - Mikrohydro, SPP - wind power (Treado, 2015), even can also be combined in a 3 sources of electrical such as solar power - wind power – mikrohydro. Solar cells are made of 2 different layers of silicon and are capable of conducting electricity. The lower layer has few electrons which are then called the Positive P type, the lower layer has more electrons and is called the Negative N type. Both of these types are limited by

an isolator so that they can not be by passed by electron flow. In conditions where the electrons can not go beyond the insulator there will be no litric flow, and when solar radiation occurs to this layer, there will be energy generating an electron jump capable of passing the insulator. The more intensity of sunlight it receives the more electron jumps will occur. From this process the occurrence of electricity.

Symptoms of radiation absorption are then converted into electrical energy like this is called PV photovoltaic (jurecka et al., 2006), Light can provide enough energy to enlarge the number of holes in the P and the number of electrons in the N section. Based on these PV phenomena can be created electronic components PV cell.

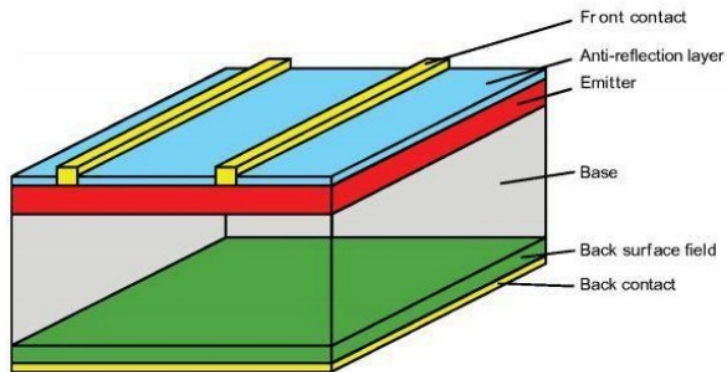

Fig. 3. Section of Solar Cell (Vozel, 2011)

In simple way the workings of this solar cell can be seen to the diagram in

Figure 4. System work of solar cell below.

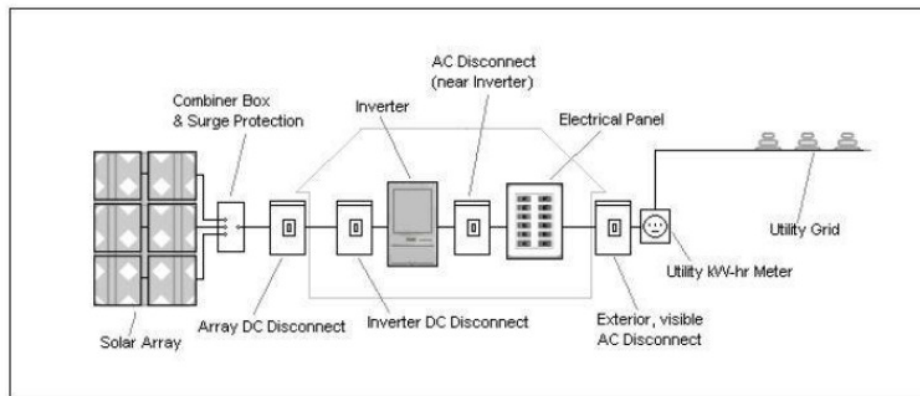

Fig. 4. Work system of solar cell (Roos & Nelson, 2009)

Solar cell consists of 2 Positive P-type layers (located below) and type N Negative (above). When type N is exposed to sunlight, the electrons in the Type N layer will jump over the insulator and move to the P type layer :

- a. When the sunlight illuminates the N-type layer, the photons will fill the layer.
- b. Photon will carry its energy entering the N type layer.
- c. Photon will transfer its energy to the electron particle in the P type layer.

- d. The electrons will jump over the insulator and move to the N-type layer and escape to the circuit.
- e. Electron motion in this circuit which then generates electrical energy.

In addition to solar energi which include renewable energy in this research is wind energy. Wind energy is an energy generated from the movement of air that move because of the influence of meteorologic law. The pressure difference between the different

places causes the wind shifts from high pressure toward the low pressure region. The movement of air or wind is then used to convert into electrical energy. In the energy capture of wind, often use the windmills are usually in the coastal areas and mountains, due to the rotating blades required wind speed of 2 meters / second, whereas to obtain a

stable electricity needed wind with a speed of 6-10 m / s , so the placement of these windmills should be taken into account where the region has a high wind intensity. Utilization of wind energy has been supplying 5% of the world's energy needs based on data in 2016 (Mwaniki et al., 2017).

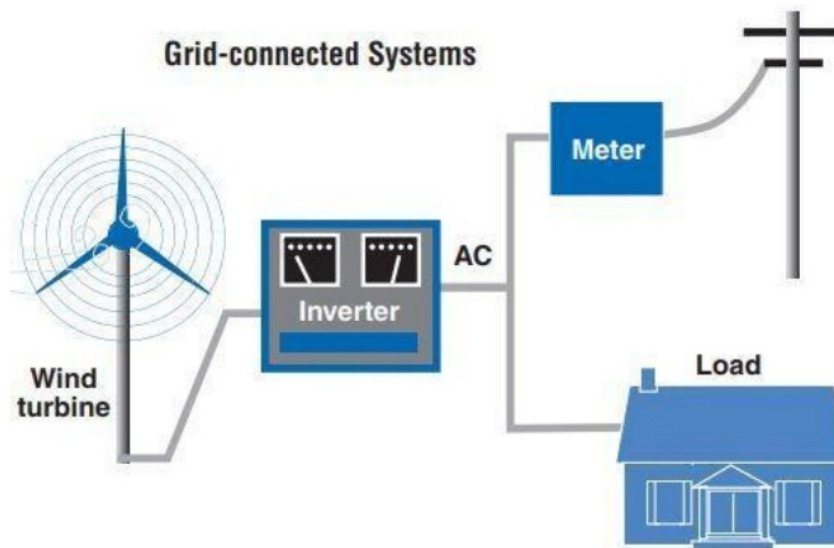

Fig. 5. Wind energy schema (Laboratory, 2007)

In some countries that have developed wind potential as a source of power, one way to increase the capacity of wind power consumption is to utilize an energy storage facility for storing electricity during a wind power surplus period (Rong et al., 2015). The stored electrical energy can be utilized at other times when wind energy can not produce abundant electrical energy production. In addition to providing an economic value to the cost of wind powered electricity production it must also calculate the layout and area of the windmill built (Knapp & Ledenburg, 2015).

This study uses a Cost Benefit Analysis CBA, where this method is often used in the

project development investment (transport infrastructure, waste management, research centers, land improvement, production or distribution of electricity) are expected to provide advantages and effects on other sectors such as local economic development or regional, optimization of transport flows but may also have negative effects such as population displacement, noise and environmental modifications (Andrei et al., 2009). This method aims to provide a comparison between the costs and the benefits of a project activity, with the following characteristics:

- a. Gives a comparison between the costs and benefits in a common project, the impact will be felt by the people, including things - other things that can not be measured by the value of the currency.
- b. Analyzing the benefits which the benefit must have a value greater than zero which means that benefits should be greater than the total cost required. And the value of these benefits should be the largest among the alternative value of the other benefits that can be implemented in a common project.

Step - a step in the use of CBA method consists of 8 steps (Andrei et al., 2009) that is :

- a. Identification of projects to create a scenario and an alternative choice.
- b. Identify the parties will receive the benefits and bear the costs
- c. Evaluating the impact it will have and determine indicators of measurement
- d. Taking into account the quantitative effect as long as the project is still worthwhile.
- e. Determining the effects of monetary value
- f. Upgrading the benefits and costs
- g. Calculating the net economic value of a project
- h. Risk and sensitivity analysis

Turning to the ELECTRE method which is also used as a method in this study, is one of the MADM methods are determined by

perangkingan to value - value pairs criteria (Yan & Min, 2016), The method was developed in Europe in the 1960s, its use when the need for decision-making in many cases with little consideration criteria. Step - a step in the method ELECTRE-II as follows:

- a. determine the normal value for all criteria. The formula in this step
- $$\frac{1}{n} \sum_{j=1}^n \frac{1}{w_j} \quad (1)$$

This formula can not be used if the criteria contained one number from any fees, unless the criteria are changed prior to the scale of the level of interest that ultimately all of the criteria are the criteria of profitability, with a formula that is used as follows:

$$\frac{1}{n} \sum_{j=1}^n \frac{1}{w_j} \quad (2)$$

if j is the advantage / benefit, and

$$\frac{1}{n} \sum_{j=1}^n \frac{1}{w_j} \quad (3)$$

if j is an attribute of the cost / cost

- b. Calculating the decision matrix paired with the formula:
with w_j is the weight of the interests of criteria to
- $$j \quad (4)$$

- c. Develop a matrix of concordance and discordance. The formula to determine the concordance index is as follows:

$$C(j, k) = \frac{1}{n} \sum_{j=1}^n \frac{1}{w_j} \quad k = 1, 2, \dots, n.$$

$$J \neq k \quad (5)$$

The formula for the index
Disconcordance:

$$d(j, k) = 0$$

if $(j) \geq (k)$

$$(6)$$

$j, k = 1, 2, \dots, k \neq nj$

By (A_j) is the value of alternative j
on criteria i .

- d. By setting three-level reduction of the threshold value concordance P^* , P_0 , P ($0 = P = P_0 = P^* = 1$) and $0 < q_0 < q^* < 1$ indicates no decrease in the level 2 on the threshold value disconcordance, decision makers can determine the relationship between strong outranking with the weak.

Strong outranking relationship is defined as follows:

$$c(j, k) \geq p^* \text{ and } d(j, k) \leq q^* \text{ and } W^+ \geq W^-$$

$\geq W^-$

for weak outranking relationship is defined by

$$c(j, k) \geq p^- \text{ and } d(j, k) \leq q^- \text{ and } W^+ \geq W^-$$

- e. Developing a graph representing the relationship of dominance among alternative

- f. Determining alternative priority

The purpose of this research can be explained into several parts that are research sourcing of renewable energy as an alternative solution for the

problem in the absence of electrical energy in Romang Island and to tap into investment for the owners of capital.

3. RESULTS AND DISCUSSION

Furthermore, it can be considered the result of calculations on the economic aspects of each sources of electricity:

a. SPP

Table 1. Power Cost Calculation SPP

Calculation	Interest rate		
	5%	9%	11%
Power costs	124,645,666.67	124,645,666.67	124,645,666.67
Operation Age (Years)	20	20	20
Capacity (Kw)	600	600	600
Capital Cost (US \$ / Kwh)	2084.27	2482.00	2767.97
O and M costs (US \$ / Kwh)	447.97	447.97	447.97
Total Cost (US \$ / Kwh)	2532.24	2929.97	3215.07
Profit 10%	2785.46	3222.97	3536.58
Investment (USD)	74,787,400,000.00	74,787,400,000.00	74,787,400,000.00

b. PLTB

Table 2. Power Cost Calculation PLTB

Calculation	Interest rate		
	5%	9%	11%
Power costs	168,852,333.33	168,852,333.33	168,852,333.33
Operation Age (Years)	20	20	20
Capacity (Kw)	600	600	600
Capital Cost (US \$ / Kwh)	2819.02	3373.19	3758.70
O and M costs (US \$ / Kwh)	447.97	447.97	447.97
Total Cost (US \$ / Kwh)	3266.99	3821.16	4206.67
Profit 10%	3593.69	4203.28	4627.34
Investment (USD)	101,311,400,000.00	101,311,400,000.00	101,311,400,000.00

c. NPV calculation of financial feasibility test SPP

Table 3. Calculation of NPV and IRR for the thermal power station SPP

NPV and IRR	NPV			IRR		
	6%	9%	11%	6%	9%	11%
Solar power	Rp 135,189,336,609.7	Rp 119,259,549,108.2	Rp 111,332,148,055.4	24 %	28 %	31 %
Wind power	Rp 174,985,410,781.9	Rp 156,111,067,510.2	Rp 146,025,482,870.7	23 %	28 %	31 %
	8	1	7			
Decent / No	NPV			IRR		
	6%	9%	11%	6%	9%	11%

	17					
Solar power	feasible	feasible	feasible	feasible	feasible	feasible
Wind power	feasible	feasible	feasible	feasible	feasible	feasible

In the table above calculation shows that the NPV and IRR for both types of generation are feasible development.

d. Ranking with ELECTRE III Method

Results of ranking according to the method ELECTRE can be seen in Table 4 below

Table 4 Aggregate Dominant matrix

	alternative 1	alternative 2
alternative 1	0	1
alternative 2	0	0

4. CONCLUSIONS AND RECOMMENDATIONS

a. Conclusion

The results of this study indicate that Romang Island holds the potential of renewable energy, with details for the solar power potential of 5.1 kWh / m2 and wind of 5.1 m / s. This potential is feasible to be used for solar power generation and wind power generation fired plant.

While the results of the calculation of NPV and IRR calculations show numbers for SPP is Rp 135,189,336,609.72 (interest rate of 6%), Rp 119,259,549,108.26 (9% interest), Rp 111,332,148,055.47 and fired plant is USD 174 985 410 781, 98 (6% interest), Rp 156,111,067,510.21 (9% interest), Rp 146,025,482,870.77 (11%).

IRR for the SPP is 24% (6% interest), 28% (9% interest), 31% (11%) and thermal power station is 23% (6% interest), 28% (9% interest), 31% (interest 11%). This result deserves to be

developed against both types of these plants.

From the calculation of the value of investments to both types of power plants are using CBA showed that the development of SPP provides greater benefits than the wind power station.

From the results out put ELECTRE III showed a ranking of alternative electoral powerhouse of renewable energy is solar power plants (SPP).

b. Suggestion

Required active role between central and local government to attract investors in order to ensure the availability of sufficient electricity, good quality at a reasonable price, in order to realize the welfare and prosperity of the people in a fair and equitable and to realize a sustainable national development, in accordance with the Laws of the Republic Indonesia Number 30 / 2009 on Electricity.

To be carried out research and identification of sources of renewable

energy on the islands that has a low electrification ratio to meet the needs of a sustainable electrical energy.

REFERENCES

Aditya & Addin, 2017. Mataloko Geothermal Power Plant Development Strategy in order to Maintain the Sustainability of Supply and Demand Electric Energy in Kupang, East Nusa Tenggara (A SystemDynamics Framework). *JGEET: Journal of Geoscience, Engineering, Environment and Technology*, II(3), pp.224-29.

Andrei, P., Valentin, M., Marius, P. & Delia, G., 2009. Methodological Approaches in Realizing and Applying Cost-Benefit Analysis For The Investment Projects. *Annals of the University of Oradea: Economic Science.*, II(1), pp.156-62.

Banerjee, R. & Choudhury, B.K., 2015. Optimization of the Building Energy Performance through Dynamic Modeling, Systems Simulation, Field Monitoring and Evaluation of Renewable Energy Applications. *International Journal of Engineering Research and Application*, V(2), pp.30-37.

Best, Rohan, Burke & J., P., 2017. The Importance of Government Effectiveness for Transitions toward Greater Electrification in Developing Countries. *Energies*, X(9), p. Doi 10.3390/em 10091247.

Birol, f., Bromhead, A., Blasi, A. & Ikeyama, S., 2015. *Southeast Asia Energy Outlook*. World Energy Outlook Special Report. Paris France: International Energy agency International Energy Agency.

Diana, P., 2012. Environmental Implications Of The Increasing Demand For Energy. *Annals of*

the University of Oradea: Economic Science, I(1), pp.358-64.

Gabbar, H.A., Bedard, R. & Ayoub, N., 2016. Integrated modeling for optimized regional transportation with compressed natural gas fuel. *Alexandria Engineering Journal*, LV(1), pp.533-45.

Gao, L. & Winfield, Z.C., 2012. Life Cycle Assessment of Environmental and Economic impacts of Advanced Vehicles. *Energies*, V(3), pp.605-20.

Jurecka, S., Pincik, E. & Brunner, R., 2006. Thin Film Solar Cells and their Optical Properties. *Advances in Electrical and Electronic Engineering*, V(1), pp.347-49.

Knapp, L. & Ledenburg, J., 2015. How Spatial Relationships Influence Economic Preferences for Wind Power—A Review. *Energies*, VIII(6), pp.6177-201.

Laboratory, D.N., 2007. *Small Wind Electric Systems*. U.S. Department of Energy.

Mandal, S., Sarker, M.R.I., Rahman, M.S. & Beg, M.R.A., 2017. An Analysis of Braking Energy Regeneration in Electric Vehicles. *International Journal of Renewable Energy Research*, VII(3), pp.999-1006.

Mazzeo, G., 2013. City and Energy Infrastructures between Economic Processes and Urban Planning. *TeMA: Journal of Land Use, Mobility and Environment*, VI(3), pp.311-24.

Mendez, B., 2016. The Calendar of the Sky. *Astronomy Beat*, 29 January. pp.1-7.

Mwaniki, J., Lin, H. & Dai, Z., 2017. A Condensed Introduction to the Doubly Fed Induction Generator Wind Energy Conversion

Systems. *Journal of Engineering*, 2017, pp.1-

18.

⁸
Rong, S. et al., 2015. Optimal Allocation of Thermal-Electric Decoupling Systems Based on the National Economy by an Improved Conjugate Gradient Method. *Energies*, IX(1), pp.1-21.

Roos, C. & Nelson, M., 2009. *Solar Electric System Design, Operation and Installation*. Washington: Washington State University.

⁴
Rutkowski, G., 2016. Study of Green Shipping Technologies - Harnessing wind, waves and solar power in new generation marine propulsion system. *International Journal on Marine Navigation and safety of sea transportation*, X(4), pp.627-32.

seferaj, K., 2014. Sustainable Development Aspects in Cross-Border Cooperation Programmes: The Case of Macedonia and Albania. *Romanian Journal of European Affairs*, XIV(4), pp.44-55.

Shykinov, N., Rulko, R. & Mroz, D., 2016. Importance Of Advanced Planning of Manufacturing for Nuclear Industry.

Utilization Of Renewable Energi By Methode Of Cba (Cost Benefit Analysis) And Electre (Elimination Et La Choix Traduisant Réalité) To Analyze The Electricity Need In The State Border Area

ORIGINALITY REPORT

10%

SIMILARITY INDEX

PRIMARY SOURCES

- 1** Muhd Nor, Nik Hisyamudin, Siti Norhana Selamat, Muhammad Hanif Abd Rashid, Mohd Fauzi Ahmad, Saifulnizan Jamian, Sia Chee Kiong, Mohd Fahrul Hassan, Fariza Mohamad, and Seiji Yokoyama. "Carbon Sequestration and Carbon Capture and Storage (CCS) in Southeast Asia", Journal of Physics Conference Series, 2016. 116 words — 2%

Crossref
 - 2** Erdiwansyah, R. Mamat, M.S.M. Sani, K. Sudhakar. "Renewable energy in Southeast Asia: Policies and recommendations", Science of The Total Environment, 2019. 75 words — 2%

Crossref
 - 3** "Trends and Challenges in Maritime Energy Management", Springer Science and Business Media LLC, 2018. 34 words — 1%

Crossref
 - 4** N I B Ariffin, M A Hannan. "Wingsail technology as a sustainable alternative to fossil fuel", IOP Conference Series: Materials Science and Engineering, 2020. 29 words — 1%

Crossref
 - 5** Noriyoshi Yamada, Nobukazu Hoshi. "Experimental Verification on Asymmetric Flying Capacitor Multilevel H-bridge Inverter by Novel Control", 2018 7th International Conference on Renewable Energy Research and Applications (ICRERA), 2018. 26 words — 1%

Crossref
-

6 Md. Mizanur Rahman, Yeoh Shir Lee, Fadzlita Mohd Tamiri, Melvin Gan Jet Hong. "Chapter 7 Anaerobic Digestion of Food Waste", Springer Science and Business Media LLC, 2018 25 words — 1%

Crossref

7 Sana Salhi, Salah Salhi. "LQR Robust Control for Active and Reactive Power Tracking of a DFIG based WECS", International Journal of Advanced Computer Science and Applications, 2019 23 words — < 1%

Crossref

8 Yang Bai, Jianxing Qin, Qi Guo, Zhongkai Yi. "The Profit Influence of Additional Heat Sources on Combined Heat and Power System in Existing Peak Shaving Compensation Mechanism", IOP Conference Series: Earth and Environmental Science, 2018 22 words — < 1%

Crossref

9 Muhammad Imran Khan, Tabassam Yasmeen, Muhammad Ijaz Khan, Muhammad Farooq, Muhammad Wakeel. "Research progress in the development of natural gas as fuel for road vehicles: A bibliographic review (1991–2016)", Renewable and Sustainable Energy Reviews, 2016 21 words — < 1%

Crossref

10 Marwan Alsultan, Jungwook Jun, James H. Lambert. "Program evaluation of highway access with innovative risk-cost-benefit analysis", Reliability Engineering & System Safety, 2020 20 words — < 1%

Crossref

11 Jorg Roosen, Wim Marneffe, Lode Vereeck. "A Review of Comparative Vehicle Cost Analysis", Transport Reviews, 2015 18 words — < 1%

Crossref

12 Spearman, Pat. "Using Sustainable Development as a Competitive Strategy.", Proquest, 2015. 17 words — < 1%

ProQuest

13 Yan, Lingxiao. "Three Essays on Marine Natural Resources and

Environmental Economics.", University of Delaware, 2019, 16 words — < 1%
ProQuest

14 Dany H. Priatno, Sunaryo. "Strategies for utilizing the potential of sea energy sources as new and renewable energy in Indonesia with the quadruple helix approach", AIP Publishing, 2020, 16 words — < 1%
Crossref

15 Takashi Asaeda, Vu Thanh Ca. "Characteristics of permeable pavement during hot summer weather and impact on the thermal environment", Building and Environment, 2000, 13 words — < 1%
Crossref

16 Carinna Hockham, Supachai Ekwattanakit, Samir Bhatt, Bridget S Penman, Sunetra Gupta, Vip Viprakasit, Frédéric B Piel. "Estimating the burden of α -thalassaemia in Thailand using a comprehensive prevalence database for Southeast Asia", Cold Spring Harbor Laboratory, 2018, 12 words — < 1%
Crossref Posted Content

17 Rebecca E. Koch, Katherine L. Buchanan, Stefania Casagrande, Ondi Crino et al. "Integrating Mitochondrial Aerobic Metabolism into Ecology and Evolution", Trends in Ecology & Evolution, 2021, 11 words — < 1%
Crossref

18 Garces, Edwin. "Evaluating R&D Projects in Regulated Utilities: The Case of Power Transmission Utilities.", Portland State University, 2020, 9 words — < 1%
ProQuest

19 Y. Mishra, S. Mishra, Fangxing Li, Z. Y. Dong. "Chapter 8 Eigenvalue Analysis of a DFIG Based Wind Power System under Different Modes of Operations", Springer Science and Business Media LLC, 2010, 8 words — < 1%
Crossref

20 Venugopal Reddy Bodha, Srujana A., Narasimha Raju Kuthuri. "Predictive back-to-back SCHVC for", 8 words — < 1%

renewable wind power system for scrutinizing quality and reliability", Energy Sources, Part A: Recovery, Utilization, and Environmental Effects, 2019

Crossref

EXCLUDE QUOTES

OFF

EXCLUDE MATCHES

OFF

EXCLUDE

OFF

BIBLIOGRAPHY